

Installation instructions

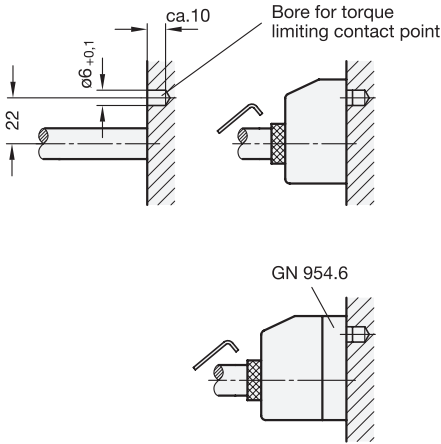

Before installation of the position indicator a bore for the torque limiting contact point is to be placed.

With the **adapter bushings GN 952.1** → Page 306, the hollow shaft (with Bore 14 H7) of the position indicator can be adapted to fit the spindle.

The mounting of the position indicator is via the torque limiting contact point which is connected to the hollow spindle and secured with a grub screw.

Before completing the installation, turn the spindle to the starting point (0) position and zero the position indicator.

With **clamping plates GN 954.6** → Page 308, spindles can be clamped and secured after adjusting.

GN 954.1 | Spacer plate

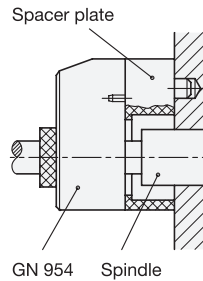
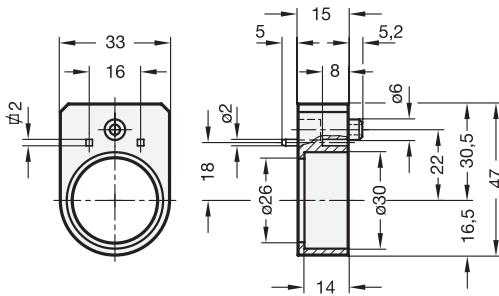

ELESA Original design BS51

Specification

- Plastic (Polyamide PA) black, matte
- RoHS-compliant



Information

The spacer plate GN 954.1 in combination with the position indicators GN 954 are used to bridge the shaft shoulders, set collars and so on.

The square bore holes are used for the machine-side fastening with e.g. socket button head self-tapping screws in accordance with DIN ISO 7049.

How to order
GN 954.1

